

Caloo Limited, Unit 9a, Triangle Business Park, Wendover Road,
Buckinghamshire, HP22 5BL, United Kingdom.
Tel: +44 (0)1296 614 448 Email: info@caloo.co.uk

Caloo Workout - CW06 Leg Press



Unit Dimensions (mm) LxWxH : 2080 x 460 x 1670

Certified by TUV
to EN 16630

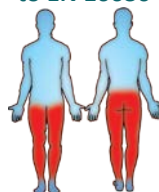

Suitable for
users over
1400mm tall.

Safety Spacing

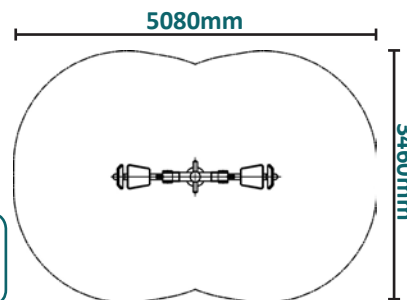

Unit Weight : 84kg Unit Free Fall Height : 1060mm
Area Needed: 5080mmx3460mm



This Caloo unit focuses on strengthening the thigh and hip muscles.

The Caloo workout Range features individual fitness stations which offer an environmentally friendly outdoor fitness facility. Each unit is designed to target a specific muscle group, creating a variety of activities which can create a full body workout or aid recuperation after accident or illness. Caloo Workout units are available in three attractive colour combinations : blue and silver, green and silver or red and yellow.

(Surface diagram to scale 1:100 on A4)
(User diagram shows unit with a 1.8m tall adult)

