

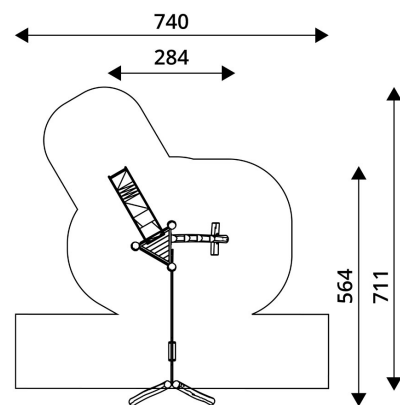

Device Specifications	
Safety zone	34,9 m ²
Length	284 cm
Width	564 cm
Total height	250 cm
Free fall height	130 cm
Age range	1-3/3-14 years
In accordance with EN standards	1176-1:2017
Weight of the heaviest part [kg]	69 kg
Dimension of the biggest part [cm]	300x18x18
Availability of spare parts	Yes

Minimal space



MATERIAL SPECIFICATION

- Construction made of Robinia - very durable acacia wood with a diameter of ~ 18 cm without sharp edges, resistant to weather conditions,
- Platforms, gangway and side panels made of Robinia - very durable acacia wood, resistant to weather conditions,
- Steel construction elements, hot-dip galvanized or hot-dip galvanized and powder-coated,
- Attested, safe seats,
- Stainless steel swing fittings,
- Calibrated stainless steel chains, preventing fingers entrapment,
- Stainless steel slides,
- Stainless steel and/or galvanized steel screws,
- Screws covered with plastic caps or stainless steel screws.

ADDITIONAL COMMENTS

- equipment intended for public playgrounds,
- equipment has a certificate issued by an accredited entity or a declaration of conformity;
- no sharp edges or chinks that would pose a danger of jimmieing the head, fingers or any other body parts;
- available types of seats in the swing: R1-flat, R2-basket, R3-flat belt, R5-flat with barrier,
- anchoring on flat surface, 80/70/60 cm deep;
- slide should not be installed southwards;
- render is for reference only, the actual appearance of the equipment and its color may vary;

SURFACES

Due to the free fall height of the equipment, the EN 1176-1:2017 standard allows the following surfaces: turf/ soil (A,B,C), sand with minimal layer thickness of 30 cm (A,C), synthetic material approved for free fall of 1,30 m