

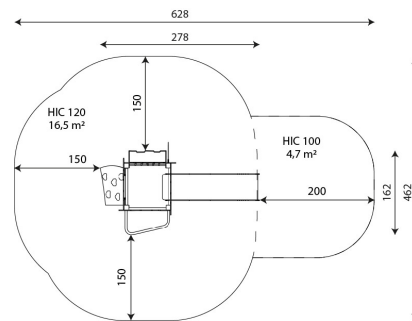

Device Specifications	
Safety zone	21,2 cm <sup>2</sup>
Lenght	278 cm
Width	162 cm
Total height	378 cm
Free fall height	120 cm
Age range	3 - 14 years
In accordance with EN standard	1176-1:2017
Weight of the heaviest part [kg]	26 kg
Dimension of the biggest part [cm]	8x8x432
Availability of spare parts	Yes

Minimal space



**MATERIAL SPECIFICATION**

- Steel structure with a profile of 80 x 80 mm, powder galvanized and powder coated or made of stainless steel,
- Platforms and climbing walls made of durable anti-slip and waterproof HPL plates
- Side panels, moving elements and flags made of HDPE plate, resistant to weather conditions,
- Screws covered with plastic caps or stainless steel screws.
- Rubber or polypropylene PP, safe end caps on top of the structure,
- Stainless steel bars and handrails,
- Fireman's pole made of stainless steel, slide made of stainless steel with HDPE side panels,
- Durable climbing stones made of polyester resin with mineral fillers.

**ADDITIONAL COMMENTS**

- equipment intended for public playgrounds;
- equipment has a certificate issued by an accredited entity or a declaration of conformity;
- no sharp edges or chinks that would pose a danger of jimming the head, fingers or any other body parts;
- anchoring on flat surface, 80/70/60 cm deep;
- slide should not be installed southwards;
- render is for reference only, the actual appearance of the equipment and its color may vary;

**SURFACES**

Due to the free fall height of the equipment, the EN 1176-1:2017 standard allows the following surfaces: sand with minimal layer thickness of 30 cm (A,C), synthetic material approved for free fall of 1,20 m (A,B,C).