



**Age Range**  
Age > 14+



**No. of Users**  
1



**Free Height of Fall**  
> 0.6m



**Assemble Time**  
1.5 H



**No. of Activities**  
2



**Impact Area**  
14.6m<sup>2</sup>

# Oblique Crunch

2306

A part of the calisthenics range that focuses on creating a stronger core, the oblique crunch allows users to place their feet under the bar to secure themselves when crunching.

Available in different colours  
(Additional charges may apply)



## Technical Information

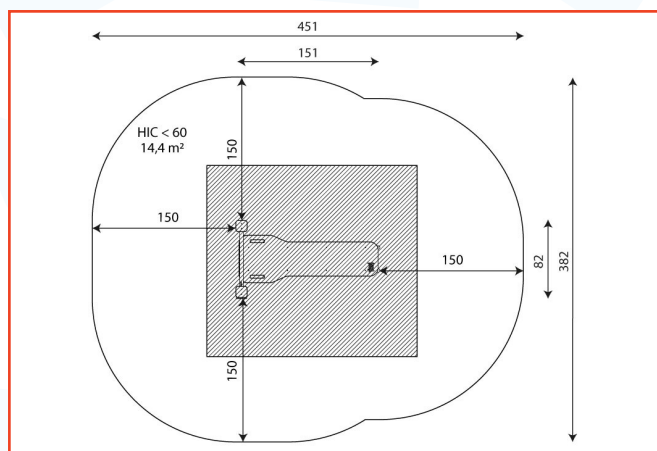

## Materials



Powder galvanized and powder-coated or stainless steel construction of 100 x 100 mm profile, durable end caps on the top of the structure made of plastic.



Aluminum exercise instructions plate screwed to HDPE plate, resistant to weather conditions.



Stainless steel bars with a diameter of 38mm for a comfortable grip during exercises.

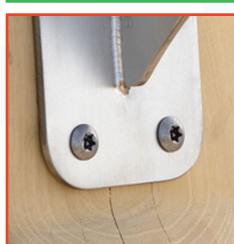

Stainless steel screws and/or screws covered with plastic caps.

## Surfacing

Grass Matting

20m<sup>2</sup>

Grass Matting (Wear Area)

6m<sup>2</sup>

Wetpour

14.6m<sup>2</sup>

## Surface Measurements

No safety surface required as critical fall height is less than 600mm. However, we suggest allowing an appropriate free space around the item in compliance with BS EN1176.

Data is subject to change without prior notice.