



**Age Range**  
Age > 14+



**No. of Users**  
5



**Free Height of Fall**  
> 2.40m



**Assemble Time**  
3.5 H



**No. of Activities**  
8



**Impact Area**  
32.6m<sup>2</sup>

# Calisthenics Workout Upper Body: Arms and Abs

2323

Calisthenic workouts are a great way to encourage your local community to exercise. This upper body Calisthenics Workout is perfect for the Arms and Abs. This particular configuration includes a pull up bar, press ups with leg raise bar, multi level press up bars and crunch bench, your outdoor gym users can target muscles in their arms, shoulders and core. Available in powder coated, galvanized steel or stainless steel construction. Stainless steel handles and screws. Aluminium plate supplied with exercise instruction. Durable, anti-slip waterproof HPL plate seat.

Available in different colours  
(Additional charges may apply)



## Technical Information

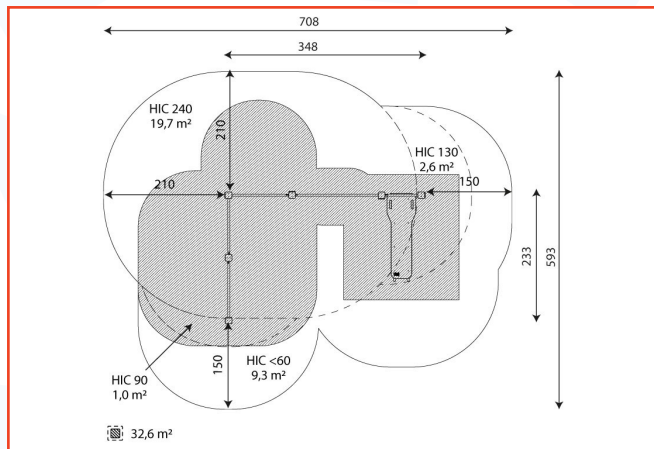

## Materials



Powder galvanized and powder-coated or stainless steel construction of 100 x 100 mm profile, durable end caps on the top of the structure made of plastic.



Aluminum exercise instructions plate screwed to HDPE plate, resistant to weather conditions.



Stainless steel bars with a diameter of 38mm for a comfortable grip during exercises.



Seats/backrests made of durable HPL plate, resistant to weather conditions.

## Surfacing

## Surface Measurements

Grass Matting	42m <sup>2</sup>
Grass Matting (Wear Area)	N/A
Wetpour	32.6m <sup>2</sup>

No safety surface required as critical fall height is less than 600mm. However, we suggest allowing an appropriate free space around the item in compliance with BS EN1176.

Data is subject to change without prior notice.