



Age Range
Age > 2



No. of Users
23



Free Height of Fall
0.9m



Assemble Time
18-19 H



No. of Activities
12



Impact Area
46.3m²

Daffodil Tower Unit

EYP-004

A large and exciting multi-play structure designed to challenge, engage, and inspire active play for a wide age range.

Constructed from durable timber and colourful HDPE, the Daffodil Tower features a wide variety of play elements, including a ramp, access steps, sloping timber bridge, stainless steel and HDPE slide, and multiple climbing and traversing challenges. Children can explore timber and HDPE traverse walls, a sleeper traverse with drop ropes and hand rope, a climb wall, and a traverse net. The structure is topped with a timber and HDPE roof, complete with polycarbonate window domes for added visual interest.

Also available with Steel Feet
(Additional charges apply)



Technical Information

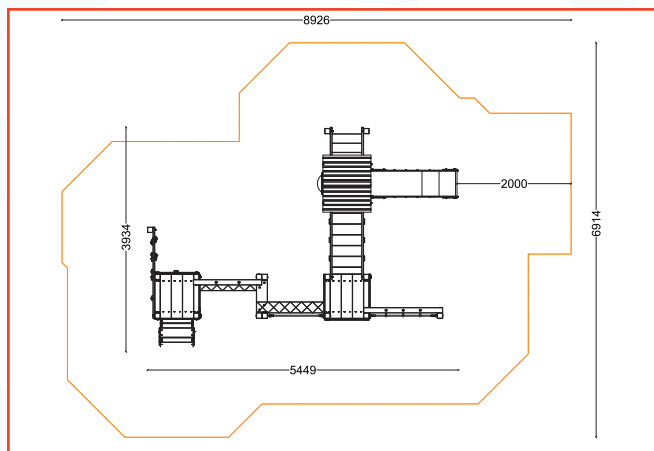

Materials



Our timber play equipment is constructed from laminated Glulam timbers for all load-bearing and structural posts. Made from European Redwood heartwood, the laminates are bonded with moisture-resistant, durable, and structurally approved adhesive, with grains aligned for maximum strength. Sourced from FSC-approved, sustainably managed European forests, Glulam ensures both safety and environmental responsibility.



Manufactured from high-grade waste which rescues countless tons of scrap from ending up in landfill. Renowned for its exceptional durability, our HDPE is virtually unbreakable, engineered to withstand the most challenging conditions. Moreover, it boasts excellent UV stability.



Our ropes are available in 10mm, 12mm, 14mm, 16mm, 24mm and 36mm diameter. The diameter of the rope is measured during manufacture whilst the rope is under tension so the finished product may have a larger diameter than stated, so be sure to make allowances for this when measuring and ordering.

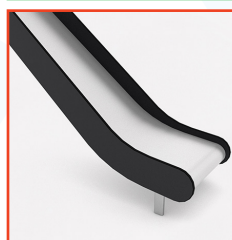

Slides are made of AISI 304 stainless steel, resistant to acts of vandalism and external factors. Our offer also includes versions made of fiberglass. The side panels of a slide are made of HDPE or HPL sheets, which are resistant to weather conditions, including frost and UV radiation.

Surfacing

Surface Measurements

Grass Matting	40m ²
Grass Matting (Wear Area)	16m ²
Wetpour	69m ²

No safety surface required as critical fall height is less than 600mm. However, we suggest allowing an appropriate free space around the item in compliance with BS EN 1176.

Data is subject to change without prior notice.